

# DATA SHEET

## **TSA6060**

### Fast radio tuning PLL frequency synthesizer

Product specification  
Supersedes data of April 1994  
File under Integrated Circuits, IC01

1995 Nov 23

# Fast radio tuning PLL frequency synthesizer

TSA6060

## FEATURES

- On-chip AM and FM prescalers with high input sensitivity
- On-chip high-performance one-input-two-output, tuning voltage amplifier for the AM and FM loop filters
- On-chip two-level current amplifier (charge pump) for loop gain adjustment
- One reference oscillator (4 or 8 MHz) for both AM and FM
- High-speed tuning provided by a powerful digital memory phase detector
- 40 kHz output reference frequency for communication between the FM/IF system and microcontroller-based tuning interface IC (TEA6100)
- Oscillator frequency range of 500 kHz to 30 MHz and 30 MHz to 200 MHz
- Four selectable reference frequencies: 1, 10, 25 or 50 kHz, for both tuning ranges
- I<sup>2</sup>C-bus interface to a microcontroller
- Software controlled band switch output
- In-lock detector output.



## APPLICATIONS

- FM mains and car radios
- VHF receivers 30 to 200 MHz.

## GENERAL DESCRIPTION

The TSA6060 is a frequency synthesizer manufactured in SUBILO-N technology (components laterally separated by oxide). The device performs all the tuning functions of a PLL radio tuning system.

The IC is designed for application in all types of radio receivers.

## QUICK REFERENCE DATA

SYMBOL	PARAMETER	CONDITIONS	MIN.	TYP.	MAX.	UNIT
V <sub>CC1</sub>	supply voltage (pin 3)		4.5	5.0	5.5	V
V <sub>CC2</sub>	supply voltage (pin 16)		V <sub>CC1</sub> + 1	8.5	12.0	V
I <sub>CC1</sub>	supply current (pin 3)	no outputs loaded	–	15	–	mA
I <sub>CC2</sub>	supply current (pin 16)	no outputs loaded	0.7	1.0	1.5	mA
f <sub>iAMmax</sub>	maximum AM input frequency		30	–	–	MHz
f <sub>iAMmin</sub>	minimum AM input frequency		–	–	500	kHz
f <sub>iFMmax</sub>	maximum FM input frequency		200	–	–	MHz
f <sub>iFMmin</sub>	minimum FM input frequency		–	–	30	MHz
V <sub>iAM(rms)</sub>	AM input voltage (RMS value)	V <sub>iFM</sub> = 0 V; f <sub>i</sub> < 15 MHz	30	–	500	mV
V <sub>iFM(rms)</sub>	FM input voltage (RMS value)	V <sub>iAM</sub> = 0 V	20	–	300	mV
P <sub>tot</sub>	total power dissipation		–	100	–	mW
T <sub>amb</sub>	operating ambient temperature		–40	–	+85	°C

## ORDERING INFORMATION

TYPE NUMBER	PACKAGE		
	NAME	DESCRIPTION	VERSION
TSA6060	DIP16	plastic dual in-line package; 16 leads (300 mil); long body	SOT38-1
TSA6060T	SO16	plastic small outline package; 16 leads; body width 7.5 mm	SOT162-1

# Fast radio tuning PLL frequency synthesizer

TSA6060

## BLOCK DIAGRAM

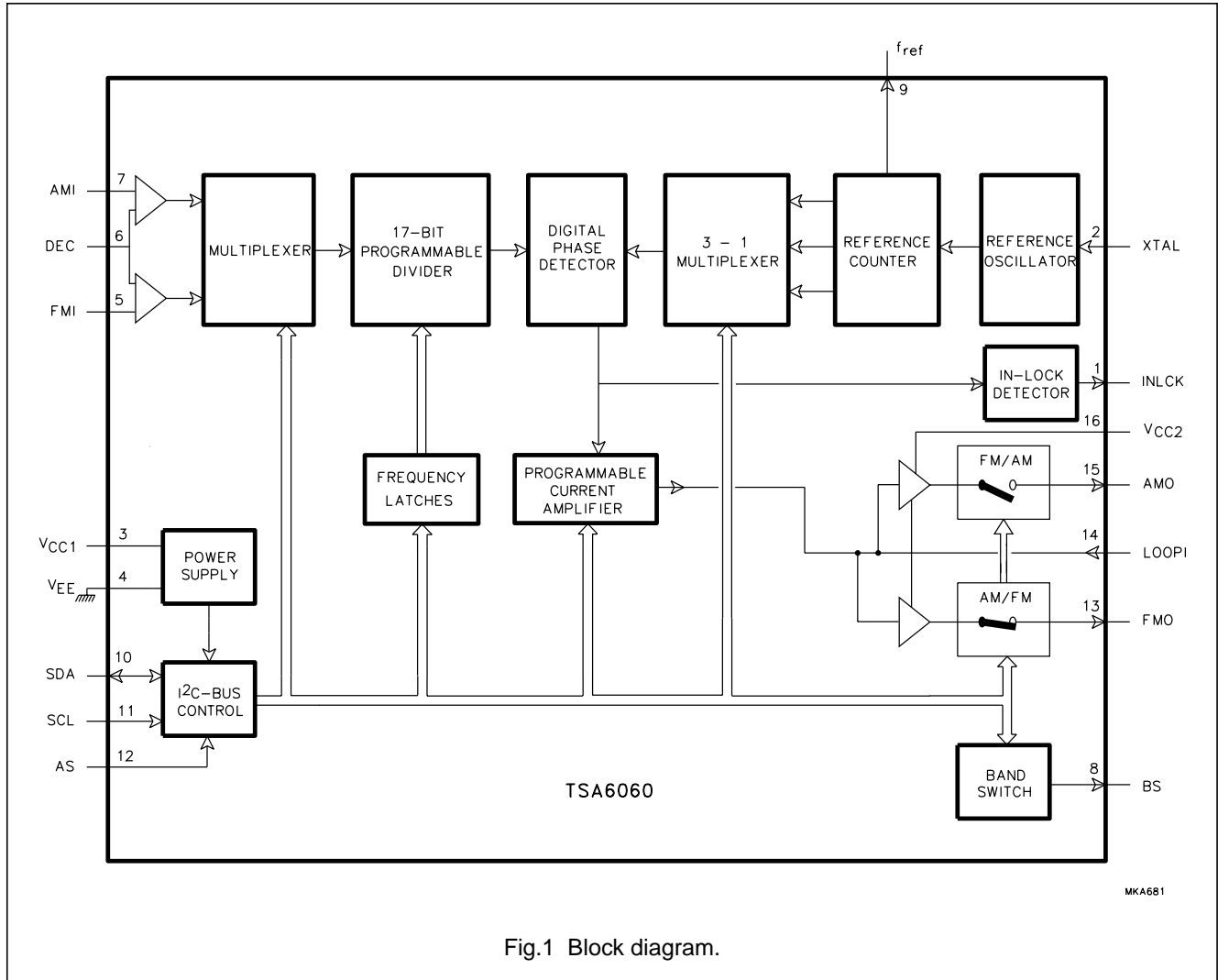

Fig.1 Block diagram.

# Fast radio tuning PLL frequency synthesizer

## TSA6060

### PINNING

SYMBOL	PIN	DESCRIPTION
INCLK	1	in-lock detector output
XTAL	2	crystal reference oscillator input
V <sub>CC1</sub>	3	supply voltage (PLL supply 1)
V <sub>EE</sub>	4	ground
FM <sub>I</sub>	5	FM VCO input
DEC	6	prescaler decoupling
AM <sub>I</sub>	7	AM VCO input
BS	8	band switch output
f <sub>ref</sub>	9	40 kHz reference output
SDA	10	serial data input (I <sup>2</sup> C-bus)
SCL	11	serial clock input (I <sup>2</sup> C-bus)
AS	12	address select input (I <sup>2</sup> C-bus)
FM <sub>O</sub>	13	FM output for external loop filter
LOOP <sub>I</sub>	14	tuning voltage amplifier input
AM <sub>O</sub>	15	AM output for external loop filter
V <sub>CC2</sub>	16	supply voltage (PLL supply 2)

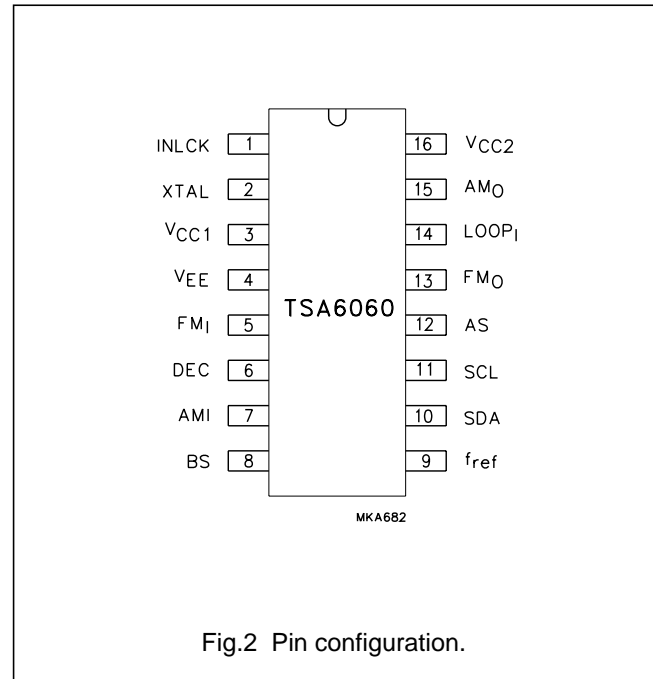

### FUNCTIONAL DESCRIPTION

The TSA6060 contains the following parts:

- Separate input amplifiers for the AM and FM VCO signals.
- A 17-bit programmable counter.
- A digital memory phase detector.
- A reference frequency channel which contains a 4 MHz or 8 MHz crystal oscillator which is followed by a reference counter. The reference frequency can be either 1, 5, 10 or 50 kHz and is applied to the digital memory phase detector. The reference counter can also output a 40 kHz reference frequency to pin 9 for communication between the FM/IF system and the microcontroller-based tuning interface IC (TEA6100).
- A programmable current amplifier (charge pump) which consists of a 25 mA and a 500 mA current source. This allows adjustment of the loop gain thereby providing high-current high-speed tuning and low-current stable tuning.
- A one-input-two-output tuning voltage amplifier. One output is connected to the external AM loop filter and the other output to the external FM loop filter. Under software control, the AM output is switched to a low

impedance to ground by the FM/AM switch in the FM position. The FM output is switched to a low impedance to ground by the AM/FM switch in the AM position. The outputs can deliver a tuning voltage of up to 10.5 V.

- An I<sup>2</sup>C-bus interface with data latches and control logic. The I<sup>2</sup>C-bus is intended for communication between microcontrollers and different ICs or modules. Detailed information concerning the I<sup>2</sup>C-bus specification is available on request.
- A software controlled band switch output.

### Controls

The TSA6060 is controlled via the 2-wire I<sup>2</sup>C-bus. For programming there is one module address, a logic 0 (R/W bit) and four data bytes. The module address contains an address select bit (AS) which enables two TSA6060s to be operated in one system.

The auto-increment facility of the I<sup>2</sup>C-bus allows programming of the TSA6060 within one transmission (address + 4 data bytes).

The TSA6060 can also be partially programmed. Transmission must then be ended by a STOP condition.

## Fast radio tuning PLL frequency synthesizer

TSA6060

The bit organization of the 4 data bytes is shown in Fig.3. Further information is given in Tables 2, 3, 4 and 5.

The bits S0 to S16 (DB0: D7 to D1; DB1: D7 to D0; DB2: D1 to D0) together with bit FM/AM (DB2: D5) are used to set the divider of the input frequency at inputs AM<sub>I</sub> (pin 7) or FM<sub>I</sub> (pin 5). If the system is in-lock the following is valid, as shown in Table 1.

**Table 1** System-in-lock (note 1).

FM/AM	INPUT FREQUENCY (f <sub>i</sub> )	INPUT
0	$(S2 \times 2^0 + S3 \times 2^1 \dots + S15 \times 2^{13} + S16 \times 2^{14}) \times f_{ref}$	AM
1	$(S0 \times 2^0 + S1 \times 2^1 \dots + S15 \times 2^{15} + S16 \times 2^{16}) \times f_{ref}$	FM

### Note

1. The minimum dividing ratio for the AM mode is  $2^6 = 64$  and for the FM mode is  $2^8 = 256$ .

**Table 2** Bit CP is used to control the charge pump current (DB0: D0).

CP	CURRENT
0	LOW
1	HIGH

**Table 5** Bit BS controls the open-collector band switch output (DB2: D2).

BS	BAND SWITCH OUTPUT
1	sink current
0	floating

**Table 3** Bits REF1 and REF2 are used to set the reference frequency applied to the phase detector (DB2: D7 to D6).

REF1	REF2	REFERENCE FREQUENCY (kHz)
0	0	1
0	1	10
1	0	25
1	1	50

The bit 8/4 MHz controls a divide-by-1/divide-by-2 divider cell in the reference oscillator section. This allows the use of a 4 MHz or 8 MHz crystal.

**Table 4** Bit FM/AM OPAMP controls the switch AM/FM, FM/AM in the tuning voltage amplifier circuits (DB2: D4).

FM/AM OPERATIONAL AMPLIFIER	SWITCH	
	FM/AM	AM/FM
1	closed	open
0	open	closed

**Table 6** Test mode.

T3	T2	T1	FUNCTION
0	X	0	normal
1	0	1	CP source
0	1	1	CP sink
1	1	1	CP 3-state
0	0	1	CP sink + source
1	1	X	BS = main divider output
1	0	X	BS = reference divider output

The data byte DB3 must be set to 0....0. It is also used for test purposes (see Fig.3).

# Fast radio tuning PLL frequency synthesizer

TSA6060

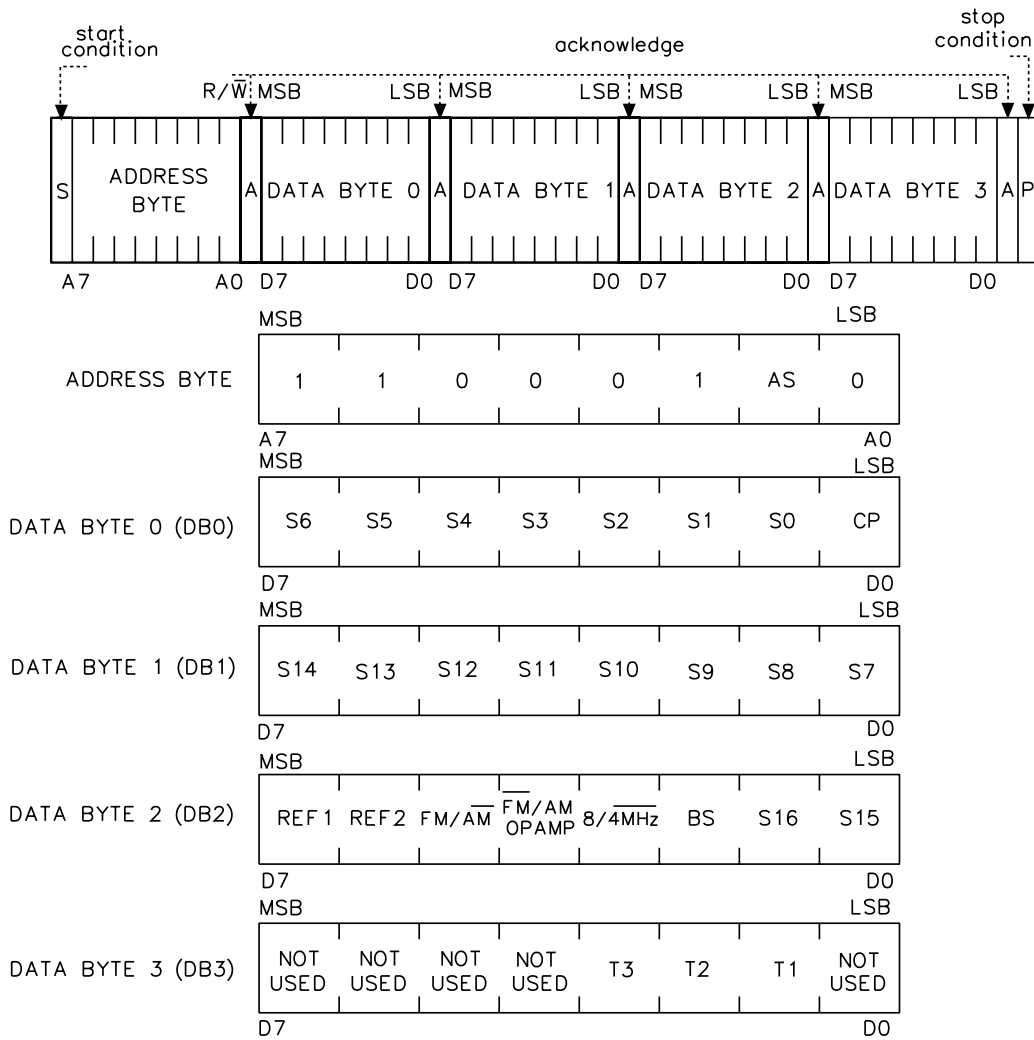

MKA683

Fig.3 Bit organization.

# Fast radio tuning PLL frequency synthesizer

TSA6060

## LIMITING VALUES

In accordance with the Absolute Maximum Rating System (IEC 134).

SYMBOL	PARAMETER	CONDITIONS	MIN.	MAX.	UNIT
V <sub>CC1</sub>	supply voltage (pin 3)		-0.3	+6	V
V <sub>CC2</sub>	supply voltage (pin 16)		V <sub>CC1</sub> + 1	12.5	V
V <sub>XTAL</sub>	crystal bias voltage		1/2V <sub>CC1</sub>	V <sub>CC1</sub>	V
P <sub>tot</sub>	total power dissipation		-	850	mW
T <sub>amb</sub>	operating ambient temperature		-40	+85	°C
T <sub>stg</sub>	IC storage temperature		-65	+150	°C
V <sub>es</sub>	electrostatic handling	note 1	-200	+200	V

### Note

1. Classification: machine model; C = 200 pF; R = 0 Ω; V = ±200 V.

## CHARACTERISTICS

V<sub>CC1</sub> = 5 V; V<sub>CC2</sub> = 8.5 V; T<sub>amb</sub> = 25 °C; unless otherwise specified.

SYMBOL	PARAMETER	CONDITIONS	MIN.	TYP.	MAX.	UNIT
<b>Supplies</b>						
V <sub>CC1</sub>	supply voltage (pin 3)		4.5	5.0	5.5	V
V <sub>CC2</sub>	supply voltage (pin 16)		V <sub>CC1</sub> + 1	8.5	12.0	V
I <sub>CC1</sub>	supply current (pin 3)	no outputs loaded	-	15	-	mA
I <sub>CC2</sub>	supply current (pin 16)	no outputs loaded	0.7	1.0	1.5	mA
<b>I<sup>2</sup>C-bus inputs: SDA and SCL (pins 10 and 11)</b>						
V <sub>IH</sub>	HIGH level input voltage		3.0	-	5.0	V
V <sub>IL</sub>	LOW level input voltage		-0.3	-	1.5	V
I <sub>IH</sub>	HIGH level input current		-	-	10	μA
I <sub>IH</sub>	LOW level input current		-	-	10	μA
<b>SDA output (pin 10)</b>						
V <sub>OL</sub>	LOW level output voltage	open collector; I <sub>OL</sub> = 3 mA	-	-	0.4	V
<b>AS input (pin 12)</b>						
V <sub>IH</sub>	HIGH level input voltage		3.0	-	5.0	V
V <sub>IL</sub>	LOW level input voltage		-0.3	-	1.0	V
I <sub>IH</sub>	HIGH level input current		-	-	10	μA
I <sub>IH</sub>	LOW level input current		-	-	10	μA
<b>INCLK output (pin 1); INCLK = HIGH; see Fig.5</b>						
V <sub>OH</sub>	HIGH level output voltage	I <sub>OH</sub> = -10 μA	V <sub>CC</sub> - 1	-	V <sub>CC</sub>	V
V <sub>OL</sub>	LOW level output voltage	I <sub>OL</sub> = 1 mA	0	-	0.4	V

## Fast radio tuning PLL frequency synthesizer

TSA6060

SYMBOL	PARAMETER	CONDITIONS	MIN.	TYP.	MAX.	UNIT
<b>RF inputs: AM<sub>I</sub> and FM<sub>I</sub> (pins 5 and 7)</b>						
f <sub>iAMmax</sub>	maximum AM input frequency		30	–	–	MHz
f <sub>iAMmin</sub>	minimum AM input frequency		–	–	500	kHz
f <sub>iFMmax</sub>	maximum FM input frequency		200	–	–	MHz
f <sub>iFMmin</sub>	minimum FM input frequency		–	–	30	MHz
V <sub>iAM(rms)</sub>	AM input voltage (RMS value)	f <sub>i</sub> < 15 MHz; measured in Fig.4	30	–	500	mV
		15 MHz < f <sub>i</sub> < 30 MHz; measured in Fig.4	40	–	500	mV
R <sub>iAM</sub>	AM input resistance		–	5.9	–	kΩ
C <sub>iAM</sub>	AM input capacitance		–	2	–	pF
V <sub>iFM(rms)</sub>	FM input voltage (RMS value)	V <sub>iAM</sub> = 0 V	20	–	300	mV
R <sub>iFM</sub>	FM input resistance		–	3.6	–	kΩ
C <sub>iFM</sub>	FM input capacitance		–	2	–	pF
<b>Oscillator (pin 2)</b>						
R <sub>xtal</sub>	crystal resonance resistance (4 or 8 MHz)	see Fig.6	–	–	150	Ω
<b>Programmable charge pump</b>						
I <sub>chp</sub>	output current to loop filter	bit CP = logic 0	16	–	30	μA
		bit CP = logic 1	400	–	600	μA
<b>Ripple rejection</b>						
SVRR <sub>1</sub>	supply voltage ripple rejection; 20 log ΔV <sub>CC1</sub> /ΔV <sub>tune</sub>	f <sub>ripple</sub> = 100 Hz	40	50	–	dB
SVRR <sub>2</sub>	supply voltage ripple rejection; 20 log ΔV <sub>CC2</sub> /ΔV <sub>tune</sub>	f <sub>ripple</sub> = 100 Hz	40	50	–	dB
<b>Band switch output: BS (pin 8)</b>						
V <sub>o(max)</sub>	maximum output voltage	programmed HIGH	–	–	12	V
V <sub>OL</sub>	LOW level output voltage	I <sub>OL</sub> = 3 mA	–	–	0.8	V
I <sub>OL</sub>	output leakage current	V <sub>OH</sub> = 12 V	–	–	10	μA
<b>Reference frequency output: f<sub>ref</sub> (pin 9)</b>						
f <sub>ref</sub>	reference output frequency		–	40	–	kHz
V <sub>OH</sub>	HIGH level output voltage	I <sub>source</sub> = 5 μA	1.2	1.4	1.7	V
V <sub>OL</sub>	LOW level output voltage	I <sub>source</sub> = 5 μA	–	0.1	0.2	V



# Fast radio tuning PLL frequency synthesizer

TSA6060

SYMBOL	PARAMETER	CONDITIONS	MIN.	TYP.	MAX.	UNIT
<b>Tuning voltage amplifiers</b>						
AM OUTPUT (PIN 15)						
$\Delta V_{OH}$	HIGH level output voltage swing	$I_O = -0.6 \text{ mA}$	$V_{CC2} - 0.9$	–	–	V
$\Delta V_{OL}$	LOW level output voltage swing	$I_O = 0.6 \text{ mA}$	–	–	0.8	V
FM OUTPUT (PIN 13)						
$\Delta V_{OH}$	HIGH level output voltage swing	$I_O = -0.6 \text{ mA}$	$V_{CC2} - 0.9$	–	–	V
$\Delta V_{OL}$	LOW level output voltage swing	$I_O = 0.6 \text{ mA}$	–	–	0.8	V
$Z_{o(off)}$	impedance of switched-off output to ground		–	500	–	$\Omega$
$ I_{bias} $	input bias current		–	1	5	nA

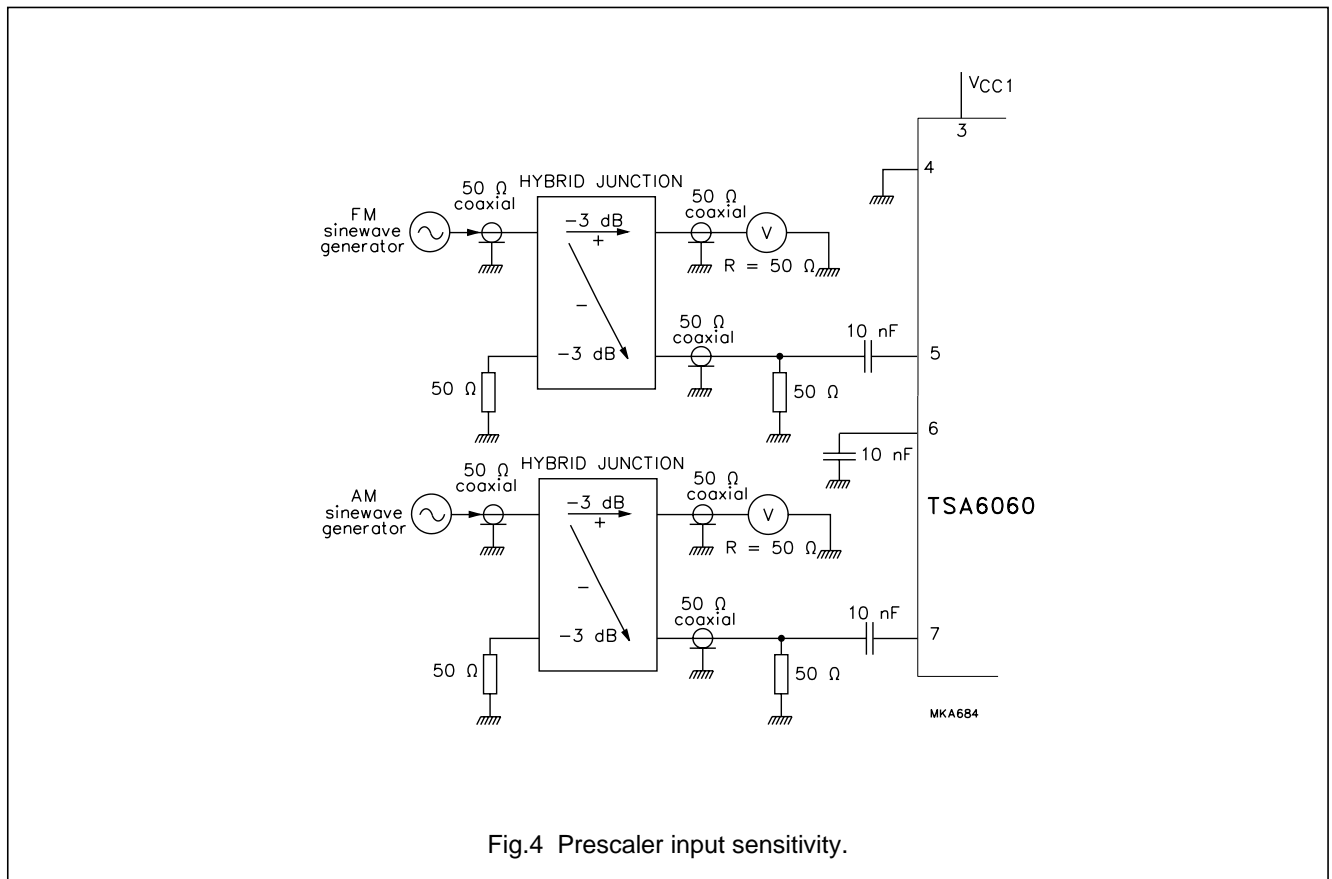

Fig.4 Prescaler input sensitivity.

# Fast radio tuning PLL frequency synthesizer

TSA6060

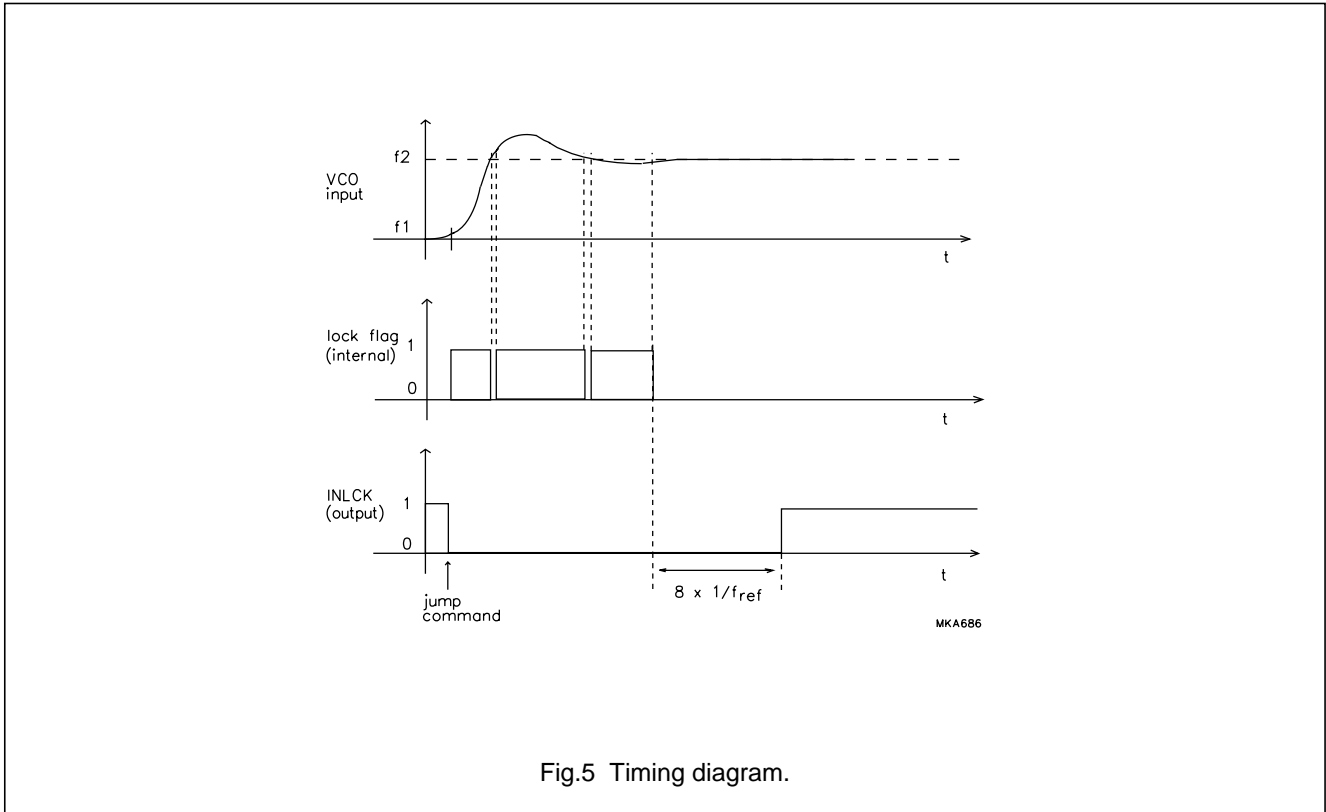

Fig.5 Timing diagram.

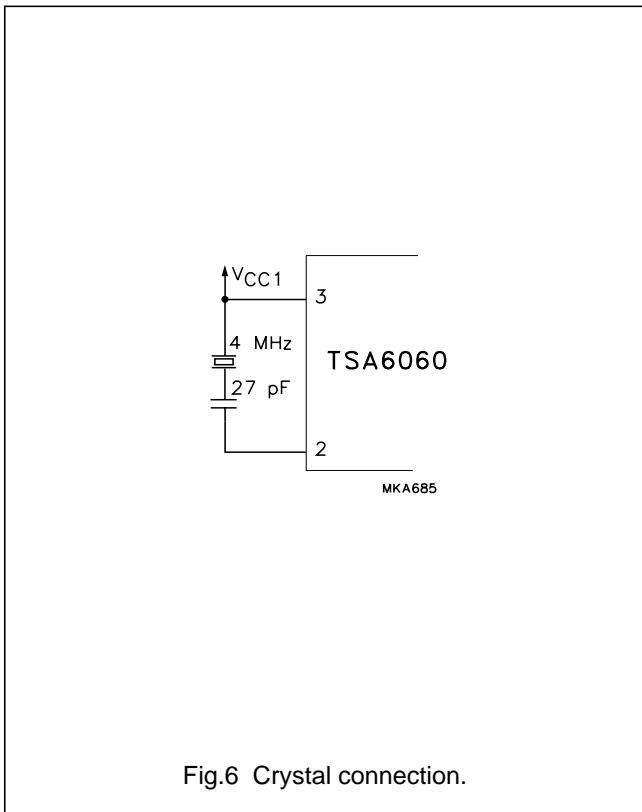

Fig.6 Crystal connection.

## APPLICATION INFORMATION

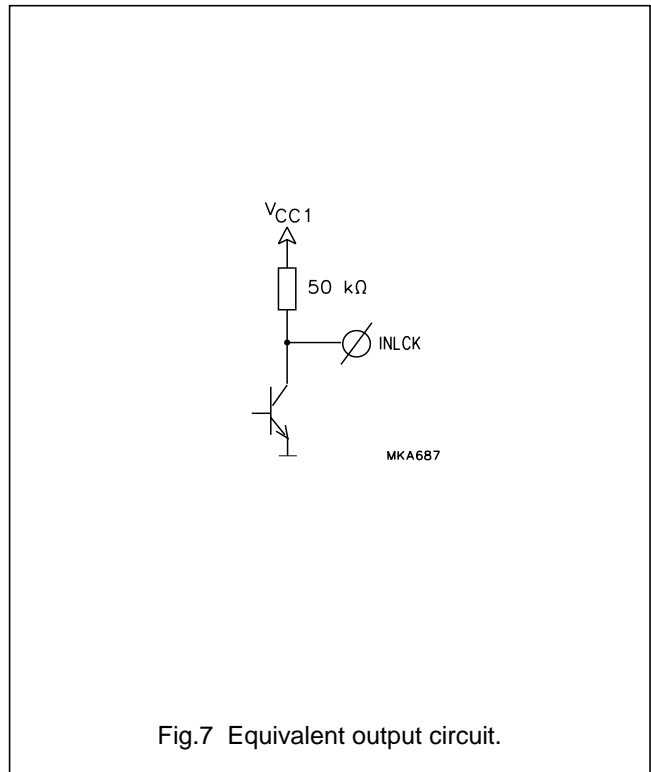
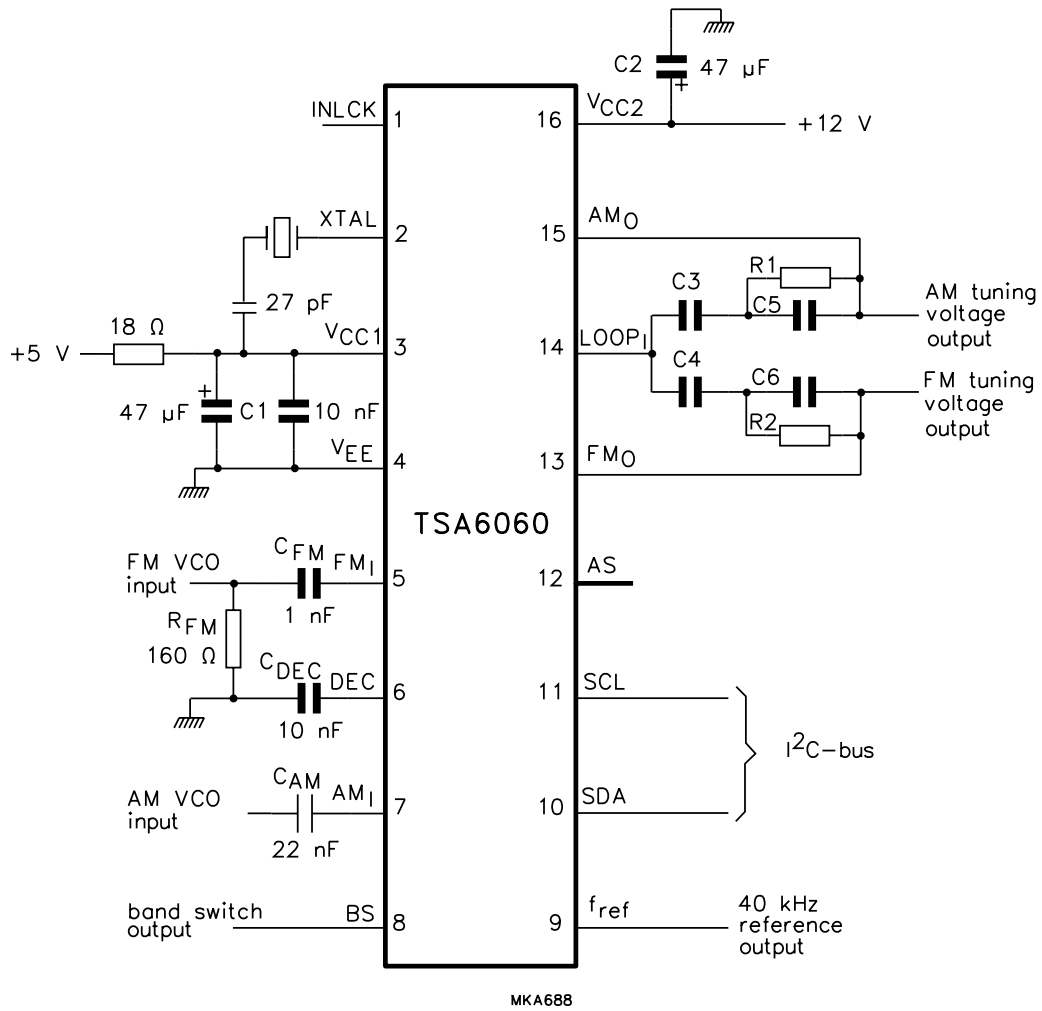

Fig.7 Equivalent output circuit.

# Fast radio tuning PLL frequency synthesizer

## TSA6060



For FM: VCO = 5 MHz/V; R2 = 10 kΩ; C4 = 68 nF; C6 = 3.9 nF.  
 For AM: VCO = 0.75 MHz/V; R1 = 47 kΩ; C3 = 440 nF; C5 = 0.47 nF.

Fig.8 Application example; loop filter dependent on VCO and tuning speed.

# Fast radio tuning PLL frequency synthesizer

TSA6060

## PACKAGE OUTLINES

DIP16: plastic dual in-line package; 16 leads (300 mil); long body

SOT38-1

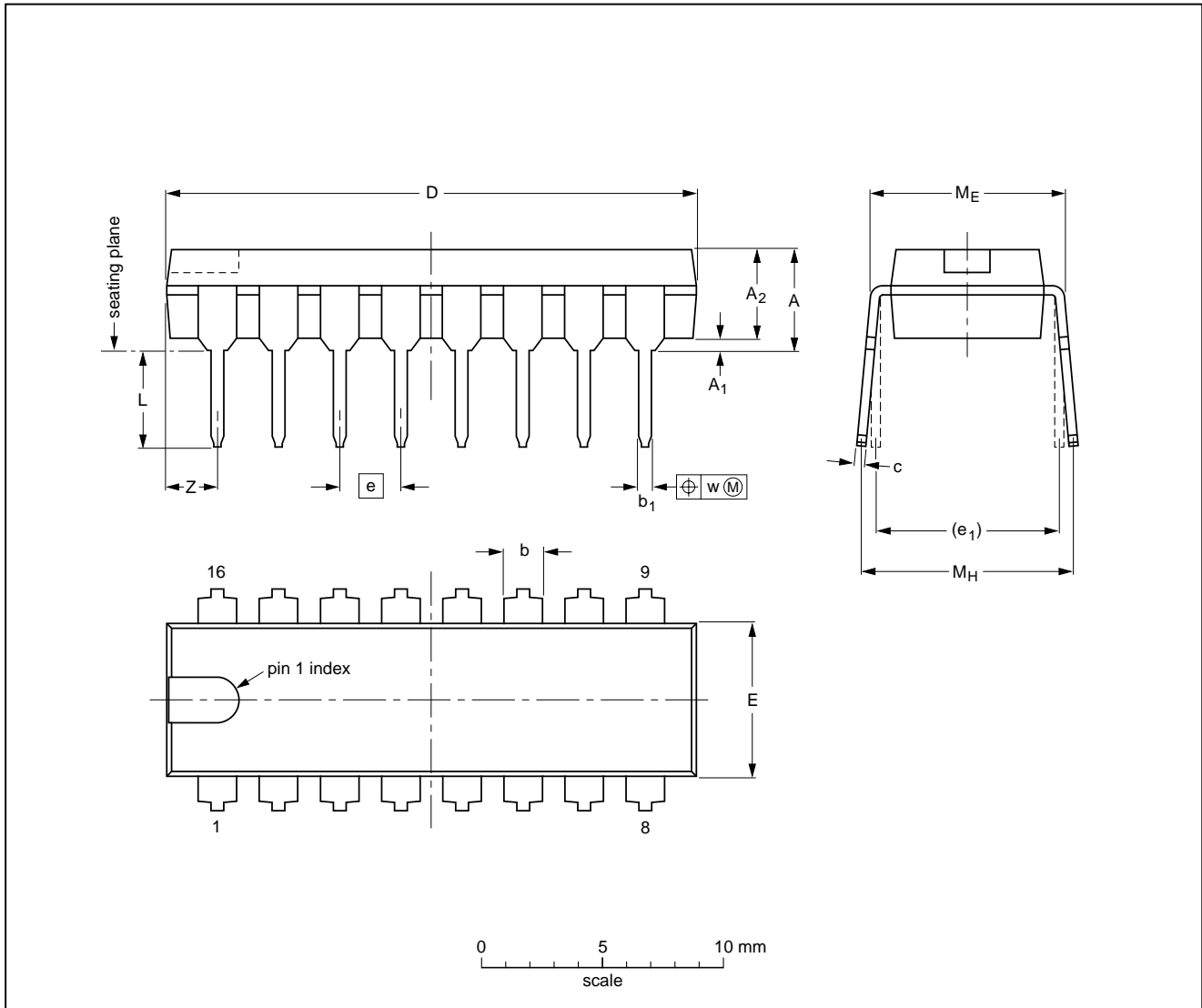

**DIMENSIONS (inch dimensions are derived from the original mm dimensions)**

UNIT	A max.	A <sub>1</sub> min.	A <sub>2</sub> max.	b	b <sub>1</sub>	c	D <sup>(1)</sup>	E <sup>(1)</sup>	e	e <sub>1</sub>	L	M <sub>E</sub>	M <sub>H</sub>	w	Z <sup>(1)</sup> max.
mm	4.7	0.51	3.7	1.40 1.14	0.53 0.38	0.32 0.23	21.8 21.4	6.48 6.20	2.54	7.62	3.9 3.4	8.25 7.80	9.5 8.3	0.254	2.2
inches	0.19	0.020	0.15	0.055 0.045	0.021 0.015	0.013 0.009	0.86 0.84	0.26 0.24	0.10	0.30	0.15 0.13	0.32 0.31	0.37 0.33	0.01	0.087

**Note**

1. Plastic or metal protrusions of 0.25 mm maximum per side are not included.

OUTLINE VERSION	REFERENCES				EUROPEAN PROJECTION	ISSUE DATE
	IEC	JEDEC	EIAJ			
SOT38-1	050G09	MO-001AE				92-10-02 95-01-19

# Fast radio tuning PLL frequency synthesizer

TSA6060

SO16: plastic small outline package; 16 leads; body width 7.5 mm

SOT162-1

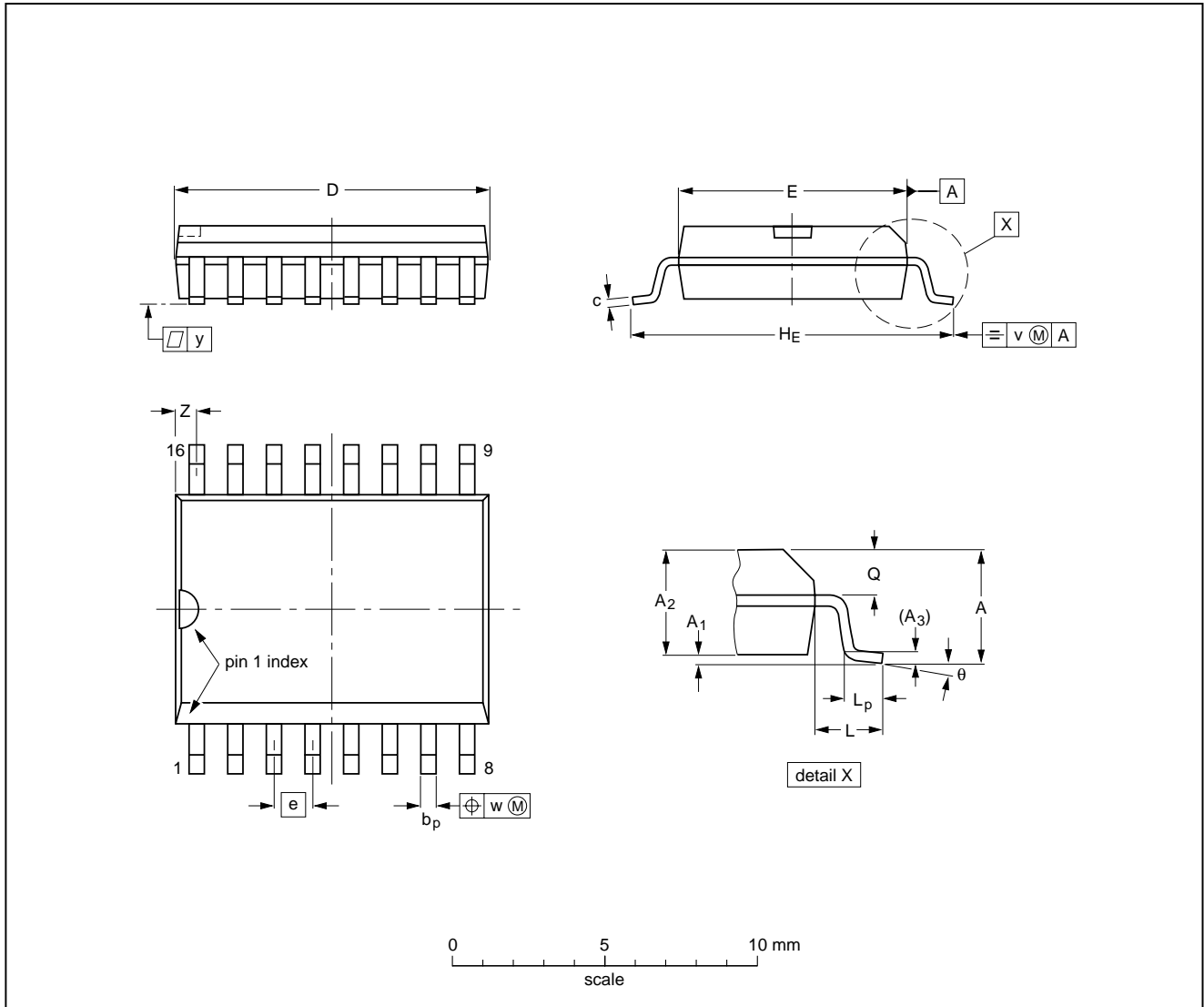

**DIMENSIONS (inch dimensions are derived from the original mm dimensions)**

UNIT	A max.	A <sub>1</sub>	A <sub>2</sub>	A <sub>3</sub>	b <sub>p</sub>	c	D <sup>(1)</sup>	E <sup>(1)</sup>	e	H <sub>E</sub>	L	L <sub>p</sub>	Q	v	w	y	z <sup>(1)</sup>	θ
mm	2.65	0.30 0.10	2.45 2.25	0.25	0.49 0.36	0.32 0.23	10.5 10.1	7.6 7.4	1.27	10.65 10.00	1.4	1.1 0.4	1.1 1.0	0.25	0.25	0.1	0.9 0.4	8° 0°
inches	0.10	0.012 0.004	0.096 0.089	0.01	0.019 0.014	0.013 0.009	0.41 0.40	0.30 0.29	0.050	0.419 0.394	0.055	0.043 0.016	0.043 0.039	0.01	0.01	0.004	0.035 0.016	

**Note**

1. Plastic or metal protrusions of 0.15 mm maximum per side are not included.

OUTLINE VERSION	REFERENCES			EUROPEAN PROJECTION	ISSUE DATE
	IEC	JEDEC	EIAJ		
SOT162-1	075E03	MS-013AA			95-01-24 97-05-22

# Fast radio tuning PLL frequency synthesizer

TSA6060

## SOLDERING

### Introduction

There is no soldering method that is ideal for all IC packages. Wave soldering is often preferred when through-hole and surface mounted components are mixed on one printed-circuit board. However, wave soldering is not always suitable for surface mounted ICs, or for printed-circuits with high population densities. In these situations reflow soldering is often used.

This text gives a very brief insight to a complex technology. A more in-depth account of soldering ICs can be found in our "IC Package Databook" (order code 9398 652 90011).

### DIP

#### SOLDERING BY DIPPING OR BY WAVE

The maximum permissible temperature of the solder is 260 °C; solder at this temperature must not be in contact with the joint for more than 5 seconds. The total contact time of successive solder waves must not exceed 5 seconds.

The device may be mounted up to the seating plane, but the temperature of the plastic body must not exceed the specified maximum storage temperature ( $T_{stg\ max}$ ). If the printed-circuit board has been pre-heated, forced cooling may be necessary immediately after soldering to keep the temperature within the permissible limit.

#### REPAIRING SOLDERED JOINTS

Apply a low voltage soldering iron (less than 24 V) to the lead(s) of the package, below the seating plane or not more than 2 mm above it. If the temperature of the soldering iron bit is less than 300 °C it may remain in contact for up to 10 seconds. If the bit temperature is between 300 and 400 °C, contact may be up to 5 seconds.

### SO

#### REFLOW SOLDERING

Reflow soldering techniques are suitable for all SO packages.

Reflow soldering requires solder paste (a suspension of fine solder particles, flux and binding agent) to be applied to the printed-circuit board by screen printing, stencilling or pressure-syringe dispensing before package placement.

Several techniques exist for reflowing; for example, thermal conduction by heated belt. Dwell times vary between 50 and 300 seconds depending on heating

method. Typical reflow temperatures range from 215 to 250 °C.

Preheating is necessary to dry the paste and evaporate the binding agent. Preheating duration: 45 minutes at 45 °C.

#### WAVE SOLDERING

Wave soldering techniques can be used for all SO packages if the following conditions are observed:

- A double-wave (a turbulent wave with high upward pressure followed by a smooth laminar wave) soldering technique should be used.
- The longitudinal axis of the package footprint must be parallel to the solder flow.
- The package footprint must incorporate solder thieves at the downstream end.

During placement and before soldering, the package must be fixed with a droplet of adhesive. The adhesive can be applied by screen printing, pin transfer or syringe dispensing. The package can be soldered after the adhesive is cured.

Maximum permissible solder temperature is 260 °C, and maximum duration of package immersion in solder is 10 seconds, if cooled to less than 150 °C within 6 seconds. Typical dwell time is 4 seconds at 250 °C.

A mildly-activated flux will eliminate the need for removal of corrosive residues in most applications.

#### REPAIRING SOLDERED JOINTS

Fix the component by first soldering two diagonally-opposite end leads. Use only a low voltage soldering iron (less than 24 V) applied to the flat part of the lead. Contact time must be limited to 10 seconds at up to 300 °C. When using a dedicated tool, all other leads can be soldered in one operation within 2 to 5 seconds between 270 and 320 °C.

# Fast radio tuning PLL frequency synthesizer

TSA6060

## DEFINITIONS

<b>Data sheet status</b>	
Objective specification	This data sheet contains target or goal specifications for product development.
Preliminary specification	This data sheet contains preliminary data; supplementary data may be published later.
Product specification	This data sheet contains final product specifications.
<b>Limiting values</b>	
Limiting values given are in accordance with the Absolute Maximum Rating System (IEC 134). Stress above one or more of the limiting values may cause permanent damage to the device. These are stress ratings only and operation of the device at these or at any other conditions above those given in the Characteristics sections of the specification is not implied. Exposure to limiting values for extended periods may affect device reliability.	
<b>Application information</b>	
Where application information is given, it is advisory and does not form part of the specification.	

## LIFE SUPPORT APPLICATIONS

These products are not designed for use in life support appliances, devices, or systems where malfunction of these products can reasonably be expected to result in personal injury. Philips customers using or selling these products for use in such applications do so at their own risk and agree to fully indemnify Philips for any damages resulting from such improper use or sale.

## PURCHASE OF PHILIPS I<sup>2</sup>C COMPONENTS



Purchase of Philips I<sup>2</sup>C components conveys a license under the Philips' I<sup>2</sup>C patent to use the components in the I<sup>2</sup>C system provided the system conforms to the I<sup>2</sup>C specification defined by Philips. This specification can be ordered using the code 9398 393 40011.

## Philips Semiconductors – a worldwide company

**Argentina:** IEROD, Av. Juramento 1992 - 14.b, (1428)  
BUENOS AIRES, Tel. (541)786 7633, Fax. (541)786 9367

**Australia:** 34 Waterloo Road, NORTH RYDE, NSW 2113,  
Tel. (02)805 4455, Fax. (02)805 4466

**Austria:** Triester Str. 64, A-1101 WIEN, P.O. Box 213,  
Tel. (01)60 101-1236, Fax. (01)60 101-1211

**Belgium:** Postbus 90050, 5600 PB EINDHOVEN, The Netherlands,  
Tel. (31)40-2783749, Fax. (31)40-2788399

**Brazil:** Rua do Rocio 220 - 5<sup>th</sup> floor, Suite 51,  
CEP: 04552-903-SÃO PAULO-SP, Brazil.  
P.O. Box 7383 (01064-970),  
Tel. (011)821-2333, Fax. (011)829-1849

**Canada:** PHILIPS SEMICONDUCTORS/COMPONENTS:  
Tel. (800) 234-7381, Fax. (708) 296-8556

**Chile:** Av. Santa Maria 0760, SANTIAGO,  
Tel. (02)773 816, Fax. (02)777 6730

**China/Hong Kong:** 501 Hong Kong Industrial Technology Centre,  
72 Tat Chee Avenue, Kowloon Tong, HONG KONG,  
Tel. (852)2319 7888, Fax. (852)2319 7700

**Colombia:** IPRELENZO LTDA, Carrera 21 No. 56-17,  
77621 BOGOTA, Tel. (571)249 7624/(571)217 4609,  
Fax. (571)217 4549

**Denmark:** Prags Boulevard 80, PB 1919, DK-2300  
COPENHAGEN S, Tel. (45)32 88 26 36, Fax. (45)31 57 19 49

**Finland:** Sinikalliontie 3, FIN-02630 ESPOO,  
Tel. (358)0-615 800, Fax. (358)0-61580 920

**France:** 4 Rue du Port-aux-Vins, BP317,  
92156 SURESNES Cedex,  
Tel. (01)4099 6161, Fax. (01)4099 6427

**Germany:** P.O. Box 10 63 23, 20043 HAMBURG,  
Tel. (040)3296-0, Fax. (040)3296 213.

**Greece:** No. 15, 25th March Street, GR 17778 TAVROS,  
Tel. (01)4894 339/4894 911, Fax. (01)4814 240

**India:** Philips INDIA Ltd, Shivsagar Estate, A Block,  
Dr. Annie Besant Rd. Worli, Bombay 400 018  
Tel. (022)4938 541, Fax. (022)4938 722

**Indonesia:** Philips House, Jalan H.R. Rasuna Said Kav. 3-4,  
P.O. Box 4252, JAKARTA 12950,  
Tel. (021)5201 122, Fax. (021)5205 189

**Ireland:** Newstead, Clonskeagh, DUBLIN 14,  
Tel. (01)7640 000, Fax. (01)7640 200

**Italy:** PHILIPS SEMICONDUCTORS S.r.l.,  
Piazza IV Novembre 3, 20124 MILANO,  
Tel. (0039)2 6752 2531, Fax. (0039)2 6752 2557

**Japan:** Philips Bldg 13-37, Kohnan2-chome, Minato-ku, TOKYO 108,  
Tel. (03)3740 5130, Fax. (03)3740 5077

**Korea:** Philips House, 260-199 Itaewon-dong,  
Yongsan-ku, SEOUL, Tel. (02)709-1412, Fax. (02)709-1415

**Malaysia:** No. 76 Jalan Universiti, 46200 PETALING JAYA,  
SELANGOR, Tel. (03)750 5214, Fax. (03)757 4880

**Mexico:** 5900 Gateway East, Suite 200, EL PASO, TX 79905,  
Tel. 9-5(800)234-7381, Fax. (708)296-8556

**Netherlands:** Postbus 90050, 5600 PB EINDHOVEN, Bldg. VB,  
Tel. (040)2783749, Fax. (040)2788399

**New Zealand:** 2 Wagener Place, C.P.O. Box 1041, AUCKLAND,  
Tel. (09)849-4160, Fax. (09)849-7811

**Norway:** Box 1, Manglerud 0612, OSLO,  
Tel. (022)74 8000, Fax. (022)74 8341

**Pakistan:** Philips Electrical Industries of Pakistan Ltd.,  
Exchange Bldg. ST-2/A, Block 9, KDA Scheme 5, Clifton,  
KARACHI 75600, Tel. (021)587 4641-49,  
Fax. (021)577035/5874546

**Philippines:** PHILIPS SEMICONDUCTORS PHILIPPINES Inc.,  
106 Valero St. Salcedo Village, P.O. Box 2108 MCC, MAKATI,  
Metro MANILA, Tel. (63) 2 816 6380, Fax. (63) 2 817 3474

**Portugal:** PHILIPS PORTUGUESA, S.A.,  
Rua dr. António Loureiro Borges 5, Arquiparque - Miraflores,  
Apartado 300, 2795 LINDA-A-VELHA,  
Tel. (01)4163160/4163333, Fax. (01)4163174/4163366

**Singapore:** Lorong 1, Toa Payoh, SINGAPORE 1231,  
Tel. (65)350 2000, Fax. (65)251 6500

**South Africa:** S.A. PHILIPS Pty Ltd.,  
195-215 Main Road Martindale, 2092 JOHANNESBURG,  
P.O. Box 7430, Johannesburg 2000,  
Tel. (011)470-5911, Fax. (011)470-5494

**Spain:** Balmes 22, 08007 BARCELONA,  
Tel. (03)301 6312, Fax. (03)301 42 43

**Sweden:** Kottbygatan 7, Akalla. S-164 85 STOCKHOLM,  
Tel. (0)8-632 2000, Fax. (0)8-632 2745

**Switzerland:** Allmendstrasse 140, CH-8027 ZÜRICH,  
Tel. (01)488 2211, Fax. (01)481 77 30

**Taiwan:** PHILIPS TAIWAN Ltd., 23-30F, 66, Chung Hsiao West  
Road, Sec. 1. Taipeh, Taiwan ROC, P.O. Box 22978,  
TAIPEI 100, Tel. (886) 2 382 4443, Fax. (886) 2 382 4444

**Thailand:** PHILIPS ELECTRONICS (THAILAND) Ltd.,  
209/2 Sanpavuth-Bangna Road Prakanong,  
Bangkok 10260, THAILAND,  
Tel. (66) 2 745-4090, Fax. (66) 2 398-0793

**Turkey:** Talatpasa Cad. No. 5, 80640 GÜLTEPE/ISTANBUL,  
Tel. (0212)279 27 70, Fax. (0212)282 67 07

**Ukraine:** Philips UKRAINE, 2A Akademika Koroleva str., Office 165,  
252148 KIEV, Tel. 380-44-4760297, Fax. 380-44-4766991

**United Kingdom:** Philips Semiconductors LTD.,  
276 Bath Road, Hayes, MIDDLESEX UB3 5BX,  
Tel. (0181)730-5000, Fax. (0181)754-8421

**United States:** 811 East Arques Avenue, SUNNYVALE,  
CA 94088-3409, Tel. (800)234-7381, Fax. (708)296-8556

**Uruguay:** Coronel Mora 433, MONTEVIDEO,  
Tel. (02)70-4044, Fax. (02)92 0601

**Internet:** <http://www.semiconductors.philips.com/ps/>

**For all other countries apply to:** Philips Semiconductors,  
International Marketing and Sales, Building BE-p,  
P.O. Box 218, 5600 MD EINDHOVEN, The Netherlands,  
Telex 35000 phtcnl, Fax. +31-40-2724825

SCD46

© Philips Electronics N.V. 1995

All rights are reserved. Reproduction in whole or in part is prohibited without the prior written consent of the copyright owner.

The information presented in this document does not form part of any quotation or contract, is believed to be accurate and reliable and may be changed without notice. No liability will be accepted by the publisher for any consequence of its use. Publication thereof does not convey nor imply any license under patent- or other industrial or intellectual property rights.

Printed in The Netherlands

513061/1100/02/pp16  
Document order number:

Date of release: 1995 Nov 23  
9397 750 00458